

# BREATHERS

## Standards

Basic protection from moisture and particulate contamination in lubricant and equipment.



## APPLICATIONS

- Totes
- Transformers
- Storage Tanks
- Hydraulics



# Overview

## Standard Breathers: Typical Industries

- Power Generation
- Mining
- Aviation
- Storage
- Manufacturing
- Petrochemical

## By the Numbers:

### 1-Domed Cap

A domed cap allows for better washdown runoff

### 2-Integrated Nylon Standpipe

The integrated standpipe provides excellent vibration resistance and dissipates impact throughout the unit, eliminating weak points. It also allows even airflow distribution throughout the unit, eliminating inaccurate readings of desiccant saturation.

### 3-External Ribs

External ribs on shell to create greater durability and grip when installing or replacing breather

### 4-Integrated Drip Ring

An integrated drip ring keeps shedding water from entering the vent holes

### 5-Threaded Mounting

Easily replaces standard filler/breather cap with multi-fit connection or one of several adapters.

### 6-Air Vents

Individual air intakes are opened based on flow requirements of the system. Plugs protect unit during shipping and storage.

### 7-Foam Pad

Foam filter captures any oil mist and disperses incoming air evenly over filtration and drying areas.

### 8-Filter Element

Polyester filter element removes airborne contamination to 3-micron absolute. Unique loops allow particles to release during system exhalation, helping to increase breather life.

### 9-Enhanced Seal

An enhanced seal eliminates potential for airflow bypass

## How It Works:

This breather unit replaces the standard dust cap or OEM breather cap on equipment. As air is drawn into equipment through the breather, the layered filter elements remove particulate while the desiccant beads strip harmful moisture.

While in service or during shut-down, the desiccant beads attract moisture from inside the equipment reservoir, actively drying the equipment.

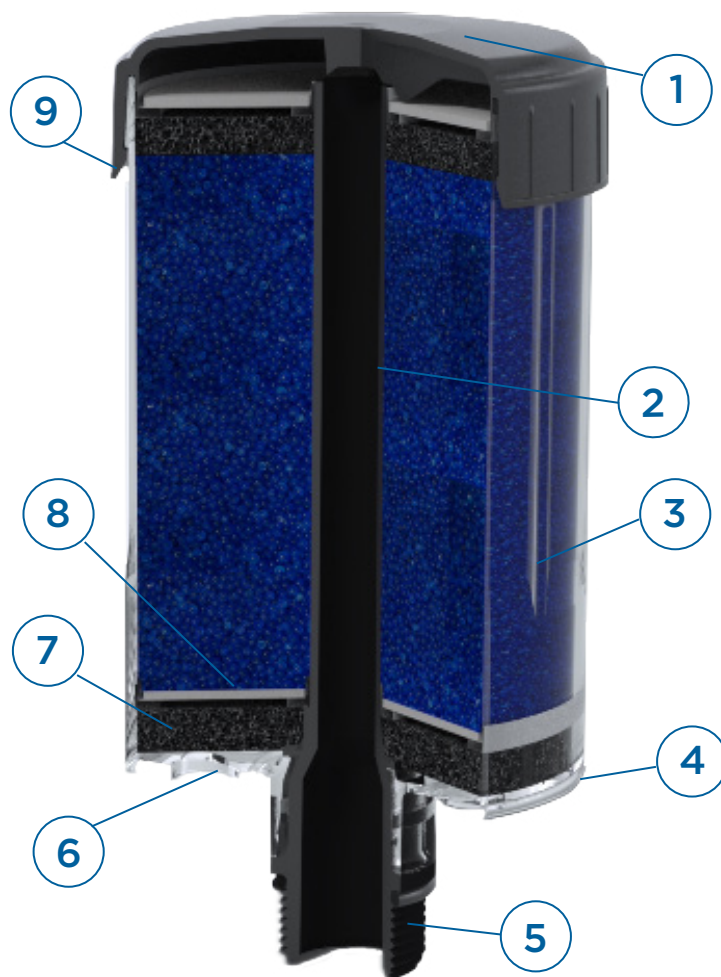

# Specifications

## Materials & Components:

**Housing:** Polycarbonate, Nylon 6/6 30% Glass Filled, Polypropylene

**Seals (DC-BB, DC-1):** Buna-N, EPDM, PVC

**Seals (DC-2, DC-3, DC-4):** Buna-N, PVC

**Filter Media:** Polyurethane, polyester

**Hydrophilic Media:** Silica gel

## Filter Efficiency:

(3 $\mu$  absolute ( $\beta_3 \geq 200$ ))

## Recommended Temperature Range:

-20°F to 200°F

-29°C to 93°C

## Chemical Compatibility:

Compatible with all mineral oils, most synthetic oils and diesel (Contact Des-Case technical support for chemical compatibility inquiries)

## Certificates and Approvals:

Upon request

	DC-BB	DC-1	DC-2	DC-3	DC-4
Amount of Desiccant:	.1 lbs / .1 kg	.3 lbs / .1 kg	.8 lbs / .4 kg	1.4 lbs / .6 kg	2 lbs / .9 kg
Adsorption Capacity:	.8 fl oz / 23 ml	1.7 fl oz / 50 ml	4.9 fl oz / 146 ml	8.7 fl oz / 257 ml	12.4 fl oz / 365 ml
Air Flow Rate:	5 @ 1 Psid	4 @ 1 Psid	16 cfm @ 1 Psid	16 cfm @ 1 Psid	16 cfm @ 1 Psid
Air Flow Rate:	11 gpm / 41 lpm	11 gpm / 41 lpm	90 gpm / 340 lpm	82 gpm / 311 lpm	75 gpm / 283 lpm

## Sizing/ Air Flow

Model	Max Suction / Return Rate (gpm / lpm)	Gearbox / Storage Tank Reservoir Size (Gallons / Liters)	Hydraulic Reservoir Size (Gallons / Liters)
DC-BB	11 / 41	15 / 57	2 / 8
DC-1	11 / 41	35 / 132	5 / 19
DC-2	90 / 340	200 / 757	60 / 227
DC-3	82 / 311	350 / 1325	100 / 379
DC-4	75 / 283	500 / 1893	200 / 757

*Please Note: This is intended as a general guideline for sizing only; other considerations, such as: humidity level, frequency of air flow, ambient temperatures, and chemical compatibility are very important in sizing a breather properly. Larger applications and special circumstances typically require the most thorough analysis. Please contact Des-Case for assistance in sizing a breather.*

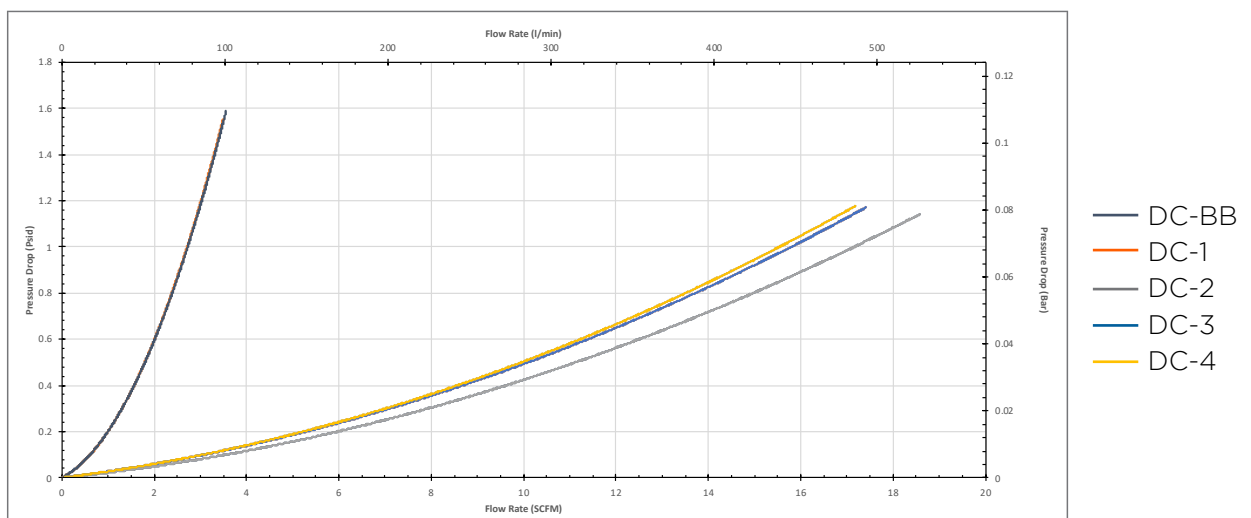

# Specifications

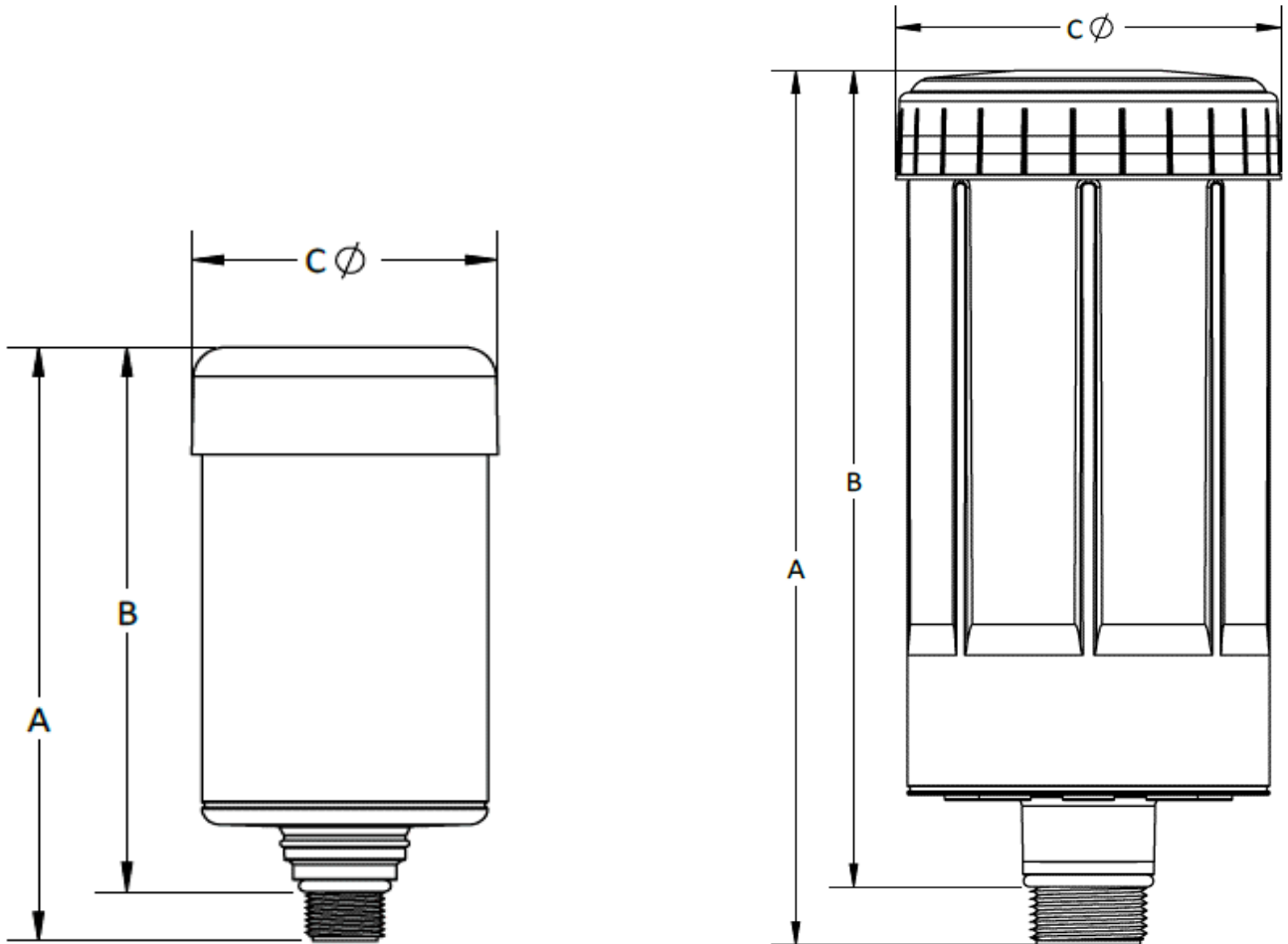

Dimension Table

Part Code	Style	A	B	C	Thread Size
	miniature or standard	inch / mm	inch / mm	inch / mm	
DC-BB	miniature	3.87 / 98	3.43 / 87	2.52 / 64	3/8" Multi-Fit Male Thread with O-Ring Seal, Compatible with: 3/8" NPT; 3/8" BSPT; 3/8" BSPP
DC-1	miniature	5.4 / 136	4.9 / 125	2.52 / 64	
DC-2	standard	6.0 / 152	5.33 / 135	4.1 / 104	
DC-3	standard	8.0 / 203	7.33 / 186	4.1 / 104	1" Multi-Fit Male Thread with O-Ring Seal, Compatible with: 1" NPT; 1" NPSM; 1" BSPT; 1" BSPP
DC-4	standard	10.0 / 254	9.33 / 237	4.1 / 104	